

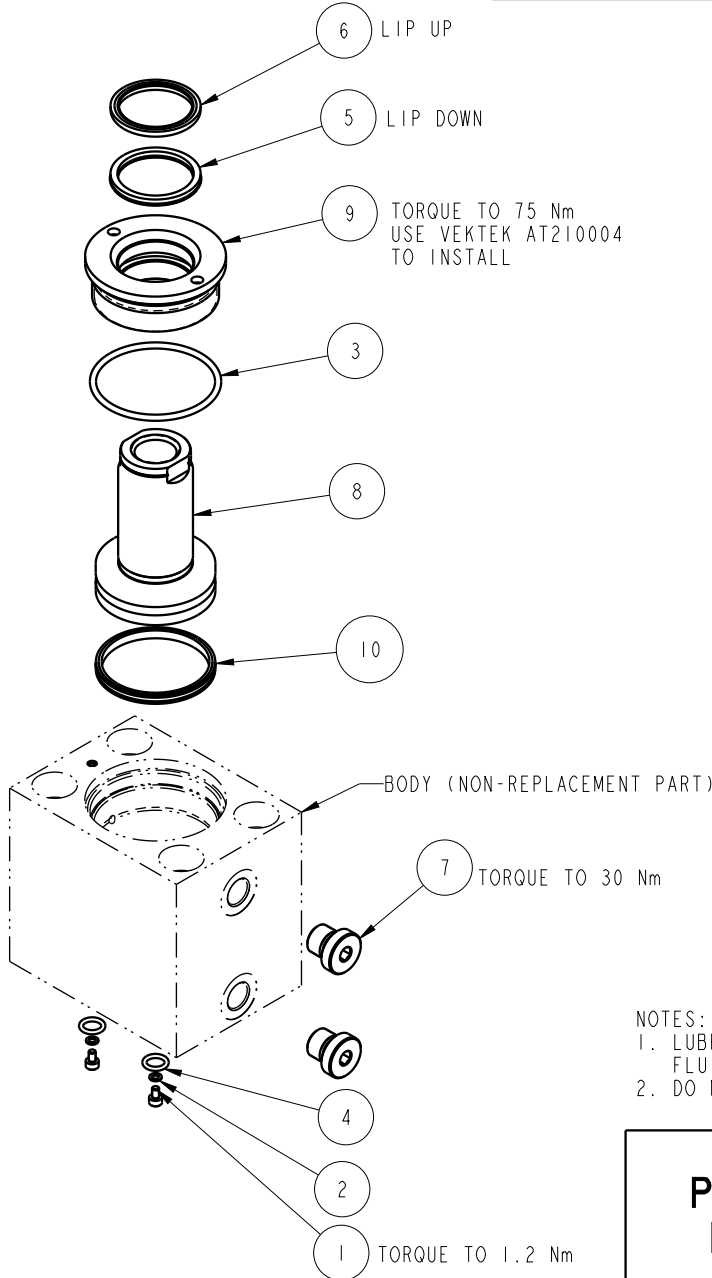

NO	QTY	PART NO	DESCRIPTION	STD SEAL KIT
1	2	21500018	SCREW, CAP, SOCH, M3 X 5, ALY	
2	2	21500200	WASHER	
3	1	39001028	O-RING, (-136)	X
4	2	39050042	O-RING, (-011)	X
5	1	39052037	SEAL, LL, (1-1/4 X 1/8 X 1/8 X 1-1/2)	X
6	1	39053057	WIPER,PRESS-IN, (1-1/4)	X
7	2	43068006	PLUG, PORT, HOLLOW HEX, G1/4	
8	1	48211018	PISTON, CYL, BB, COMBO, 70,9 KN, 25	
9	1	48211024	GLAND, CYL, BB, COMBO, 70,9 KN	
10	1	39H11032	SEAL,T, (1 13/16 X 5/32 X 2)	X
N/A	N/A	60211204	KIT, SEAL, CYL, BB, COMBO, DA, 70.9 KN	NOTED



NOTES:  
 1. LUBRICATE ALL SEALS WITH CLEAN HYDRAULIC FLUID PRIOR TO INSTALLATION.  
 2. DO NOT USE SILICONE TYPE LUBRICANTS.

<b>PARTS LIST</b>	 VEKTEK, INC. 1334 E. SIXTH AVE. P.O. BOX 625 EMPORIA, KS. 66801 U.S.A.
	ASSEMBLIES AFFECTED 42112108 L2112108
SIZE A	MPLV4208

F	4246	RELEASE	MJUST	8/4/20
REV	IN ACCORDANCE WITH ECN	EFFECTIVE DATE	REVISED BY	DATE
DRW BY:	K. ROEMER	<b>DRAWING STATUS: Released</b>		
DATE:	11/09/11	PRODUCTION APPROVED FOR RELEASED STATUS ONLY		

SHEET 1 OF 1